

D - DOORS

DESCRIPTION.

DOOR

- CUSTOM MADE ALUMINUM DOOR INWARD OPENING
- JOINTS ARE TO BE MITRED AND SECURED WITH CLEATS
- PRESSURE GLAZING GASKETS TO BE INCORPORATED INTO THE SYSTEM
- PLUGGED TO BRICKWORK OR CONCRETE.

OVERALL SIZE : SIZE 100(W)x2125(H)

FRAME

FINISH.

- POWDER COATED - COLOUR CHARCOAL

NOTES

DOOR HANDING LEGEND

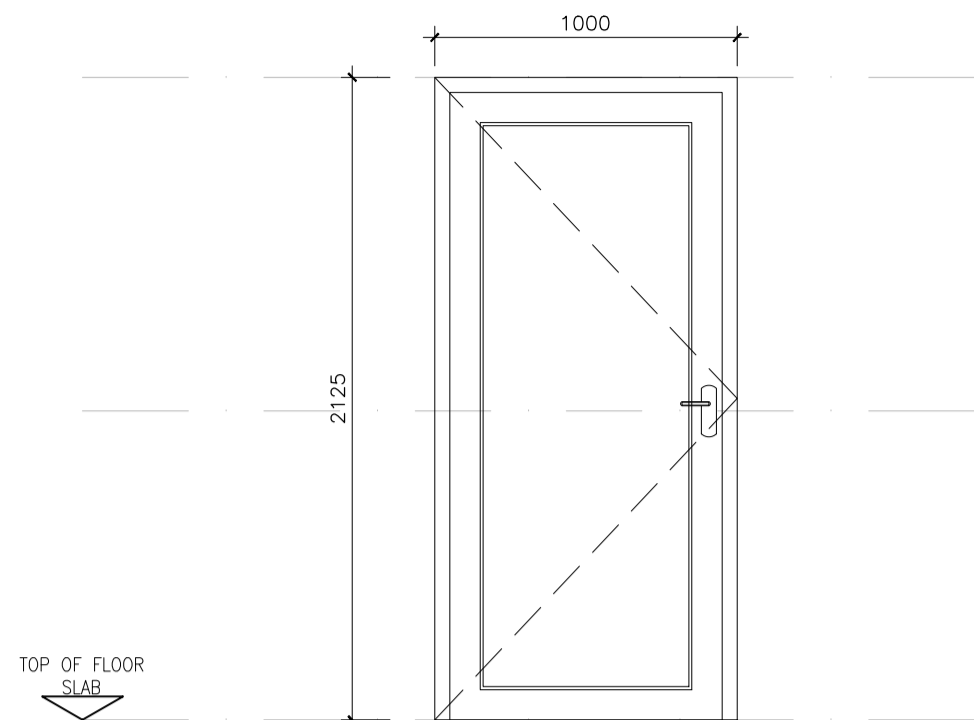
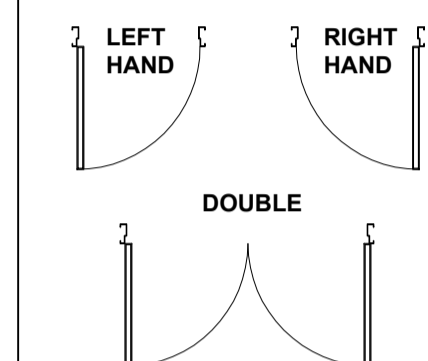

ELEVATION

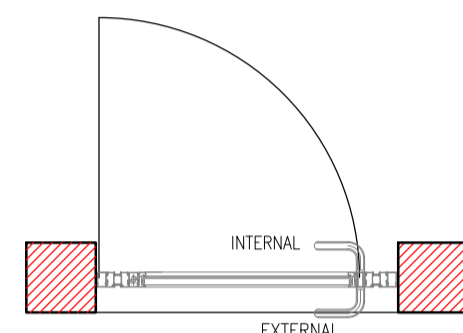

PLAN

DOOR NO'S:

D-01/GF-001;

IRONMONGERY:

QUANTITY:

Hand	Qty.	Total
LH	0	1
RH	1	

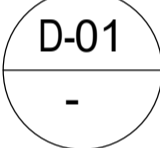

D - DOORS

DESCRIPTION.

DOOR

SWARTLAND BLUE 5 YEAR GUARANTEE 44MM THICK BQE HORIZONTAL SLATED HARDWOOD DOOR WITH NO FRAME, SIZE 813 X 2032MM HIGH (CODE: PD60).

FRAME

- SWARTLAND BLUE INTERNAL MERTANI FRAME

FINISH.

SEALED WITH A LINSEED OIL BASED TRANSIT STABILIZING SEALER, SAND DOWN TIMBER SURFACE TO A FINE SMOOTH FINISH AND APPLY THREE COATS SWARTLAND MAMCARE QUALITY TIMBER SEALANT PRIOR TO INSTALLATION, ALL IN ACCORDANCE WITH THE MANUFACTURER'S RECOMMENDATIONS.

NOTES

DOOR HANDING LEGEND

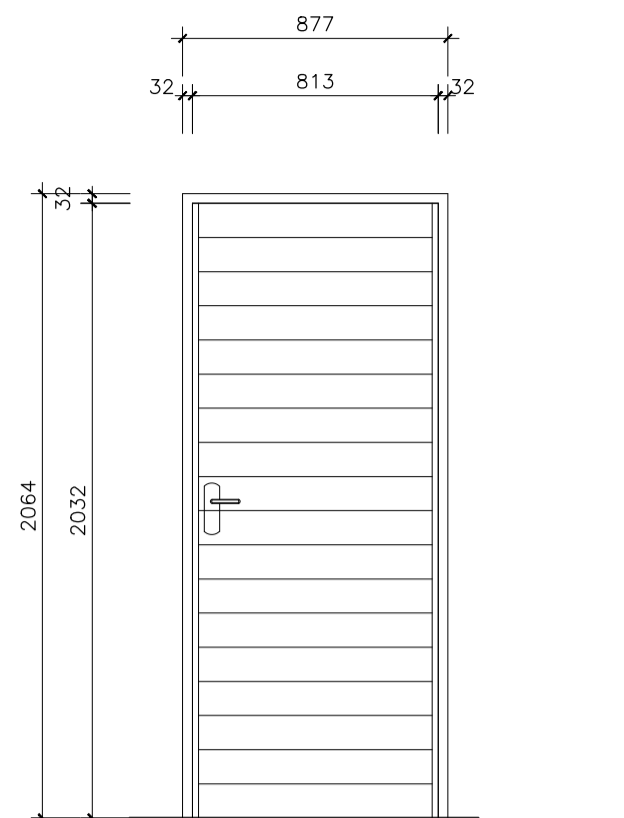
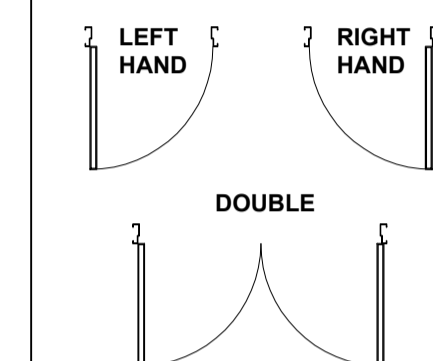

ELEVATION

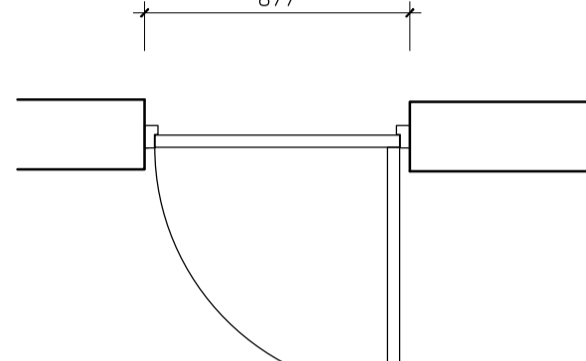

PLAN

DOOR NO'S:

D-02/GF-001;
D-02/FF-001; D-02/FF-002; D-02/FF-003; D-02/FF-004;

IRONMONGERY:

QUANTITY:

Hand	Qty.	Total
LH	3	5
RH	2	

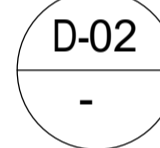

D - DOORS

DESCRIPTION.

DOOR

SWARTLAND BLUE 44MM THICK SOLID SWARTLAND GOLD 10 YEAR GUARANTEE 44MM THICK SD14S FRAMED, LEDGED AND BATTENED BOTTOM WITH FULL GLASS TOP HARDWOOD OPENING OUT STABLE DOOR. SIZE 813 X 2032MM HIGH (CODE: SD14S/00), AS SUPPLIED BY MED OR SIMILAR APPROVED BY ARCHITECT (FRAME)

FINISH.

SEALED WITH A LINSEED OIL BASED TRANSIT STABILIZING SEALER, SAND DOWN TIMBER SURFACE TO A FINE SMOOTH FINISH AND APPLY THREE COATS SWARTLAND MAMCARE QUALITY TIMBER SEALANT PRIOR TO INSTALLATION, ALL IN ACCORDANCE WITH THE MANUFACTURER'S RECOMMENDATIONS.

NOTES:

DOOR HANDING LEGEND

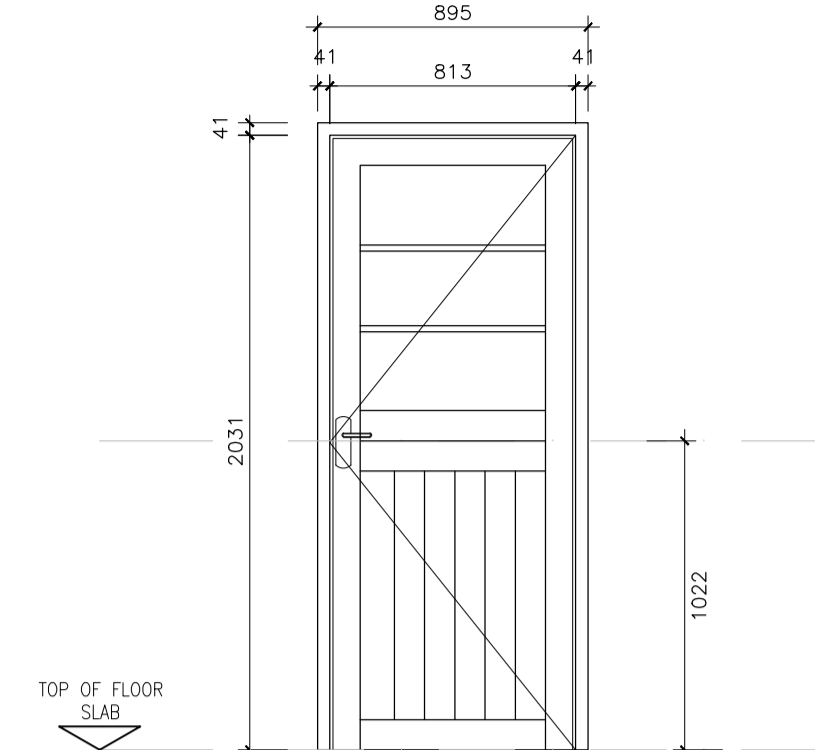
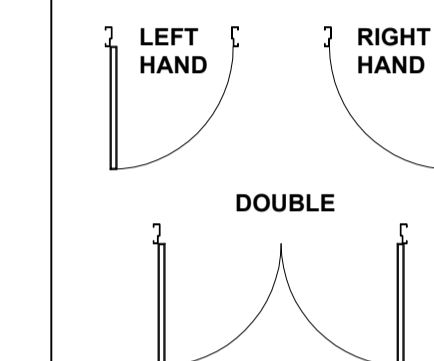

ELEVATION

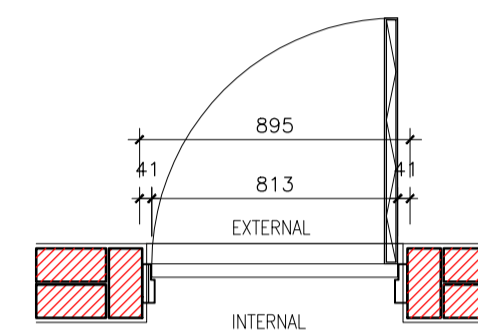

PLAN

DOOR NO'S:

D-08/GF-001;

IRONMONGERY:

QUANTITY:

Hand	Qty.	Total
LH	1	1
RH		

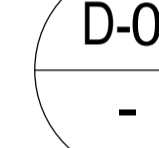

THIS DRAWING IS ISSUED FOR CONCEPT PLANNING AND PRELIMINARY COSTING PURPOSES ONLY. NOT FOR CONSTRUCTION

MUNICIPAL STAMP

COPYRIGHT NOTE

- THIS DRAWING IS SUBJECT TO COPYRIGHT AND MAY NOT BE REPRODUCED IN WHOLE OR PART, OR IN ANY MANNER WITHOUT THE WRITTEN PERMISSION FROM THE ARCHITECT
- ALL WORK TO BE CARRIED OUT STRICTLY IN ACCORDANCE WITH MUNICIPAL AND/OR LOCAL AUTHORITY REGULATIONS
- DO NOT SCALE THIS DRAWING. FIGURED DIMENSIONS TO BE TAKEN IN PREFERENCE TO SCALING DRAWING.
- ALL RELEVANT DETAILS, LEVELS AND DIMENSIONS TO BE CHECKED ON SITE PRIOR TO COMMENCEMENT OF WORK.
- ANY DISCREPANCIES TO BE BROUGHT TO THE ATTENTION OF THE ARCHITECT.

GENERAL NOTES

- ALL WORK TO COMPLY WITH NATIONAL BUILDING REGULATIONS.**
1. Indicate rooms to have min. 1.5% floor area cross ventilation.
 2. Vertical D.P.C. to all changes in floor levels.
 3. All dimensions and levels to be checked on site before any work commences.
 4. This drawing is not to be scaled and only figured dimensions are to be used.
 5. All work to be carried out in accordance with local authority requirements.
 6. All levels unless otherwise indicated are finished floor levels.
 7. Finished floor levels are to be min. 150mm above N.G.L.
 8. Any discrepancies are to be reported to the offices of the architect.

- DRAINAGE**
1. Ø100mm PVC soil pipes to min 150 fall to connect to ex. 150mm drain connected to Man. connection point.
 2. Ø100mm C.I. OVP at one before head of drain to min. 1800mm rise above window sills.
 3. Soil pipe droppers to be Ø100mm cast iron.
 4. IE's & RE's at all bends & junctions to have clearly marked covers at ground level.
 5. All waste pipes to be surface mounted.
 6. All waste pipes located under surface beds to be encased in 230mm concrete all round.
 7. All soil pipes located under surface beds to be encased in 230mm concrete all round.
 8. No bends or junctions in either soil or waste pipes to take place under surface beds.
 9. Drop in level exceeding 1200mm to be provided with 1000mm A.S. VPs.
 10. 50mm S.P. Vents & WPs to be provided where required by regulations.

- LIGHTING AND VENTILATION**
1. Areas will be either air-conditioned or mechanically ventilated by A.C. Engineers design & supervision in accordance with Part O of the N.B.R. and the Health Act (ES of 1977)
 2. Habitable rooms with no Artificial ventilation to be provided with windows of no. less than 10% in the area served with a min. opening of 5% of the floor area.

STORM WATER DISPOSAL

- FACILITIES FOR DISABLED**
1. A complete storm water system based on a rational design will be prepared by a Professional Engineer.
 1. Ramps will be provided to enable the disabled to gain access to the building. Such ramps will be min. 1200mm wide and min. 1:12 in grade with an approved non-slip surface.
 2. Doors accessing from such ramps will be min. 800mm wide with lever handles max. 1200mm above floor level.
 3. Assisted toilet compartments & bathrooms have been provided, as part of the design requirements.
 4. One 3500mm wide parking bay out 20 to be provided for disabled persons.
 5. Standard symbols will be used to indicate facilities for disabled persons.

- WATERPROOFING**
1. Approved Damp Proof Course (as SABS 248, 298, or 952) extending the full thickness of walls to be built on all walls at min. 150mm above outside ground level under all window sills & under all surface beds.
 2. Approved vertical waterproofing to be built in against all retaining walls to engineers approval.
 3. 10 Year guaranteed waterproofing laid in accordance with manufacturers specs. to be laid on all R.C. slabs.

SPACE HEATING

1. Space heating is to be incorporated in the air-conditioning system to A.C. Engineers design.
2. Roof insulation as per spec. to be laid over rafters and battens.
3. Internal stairways in reinforced concrete to struct. engineers design. Dimensions of stairs as per spec. on drawings.
4. Handrail and Balustrading to be 1000mm high from nosing Structural

- GLAZING**
1. The normal thickness of a panel of glass will not be less than that indicated in the following table -
- | GLASS THICKNESS(mm) | MAX. AREA OF PANEL(sq.m) |
|---------------------|--------------------------|
| 3 | 0.75 |
| 4 | 1.50 |
| 5 | 2.1 |
| 6 | 3.2 |
2. Glazing to doors to be 6mm Safety Glass or similar.
 3. Glazing not apparent to approaching sensors shall bear distinctive marking to render glazing more apparent.
 4. All glazing to be installed in accordance with SABS 0137 and 1263.

FIRE

1. Fire design to conform to specialist rational fire consultant proposals.
- PREPARATION OF SITE**
- (1) Before any foundation is laid the area to be covered by any building shall be properly cleared of vegetable matter, tree stumps, timber and other cellulose material, debris or refuse and any material contaminated with faecal matter.
 - (2) Where any site upon which any building is to be erected is waterlogged, seasonally waterlogged or saturated, or where any building is to be so situated that water will drain naturally towards it, drainage shall be provided to direct such water away from such site or building to a stormwater drain or to dispose of it in some other safe approved manner.
- F5 SOIL POSITIONING**
- (1) Buildings shall, where so required by the local authority or in areas of high termite infestation, be protected from subterranean termite activity.
 - (2) The requirements of sub-paragraph (1) shall be deemed to be satisfied where the means of termite protection complies with sars 10400-1.

REV. DATE. DESCRIPTION

REV.	DATE	DESCRIPTION
A	04/10/2022	FIRST ISSUE FOR CLIENT REVIEW

CLIENT

REDLINE GROUP
NEW RESIDENCES TO ERF 76533 AND 76532

PROJECT TITLE

PROPOSED DWELLING TO 24 ELFIN GLEN RD, NAHOON VALLEY PARK, EAST LONDON ERF 76533 AND 76532

CONCEPT DESCRIPTION

CONCEPTUAL DOOR SCHEDULES (SHEET 1)



Ryan Ewing 072 2744715
Pr.Arch 24740021 / B.Arch / B.Bdg.A

CONCEPT / PLANNING

ED 2205	RES
---------	-----

2205-AR - DES - 5100	A
----------------------	---

R.A.E.	R.A.E.	04/10/22	A/S
--------	--------	----------	-----